



GX DP-800™

NEW *from* Gendex!

Versatility without Compromise.

DRT 

Dose Reduction Technology™

- ☞ Cone Beam 3D Imaging Systems
- ☞ Panoramic X-ray Systems
- Intraoral X-ray Systems
- Digital Intraoral Sensors
- Digital X-ray Imaging Plates
- Intraoral Cameras
- Imaging Software

GENDEX™
Always by your side



Performance you can depend on.

To get you the vital information you need to support your accurate diagnoses. To help make your treatment planning that much more predictable. To provide you with a quality imaging solution you can truly rely on. That's what we set out to do, every single day. It's the Gendex philosophy.

And it's also why we have always made a point to work with both general practitioners and specialists. To make sure we provide imaging solutions that are comprehensive while meeting various needs. It's just the Gendex way of doing things.

By designing innovative yet day-to-day dependable imaging solutions, we strive to give you the daily dose of great performance you need to stay ahead.

GXDP-800™ Series – the next logical step.

- A flagship product for a whole new generation of Gendex products
- A cost-efficient and easy-to-use system
- Made to adapt to your requirements

GXDP-800™ Series – Your main benefits.

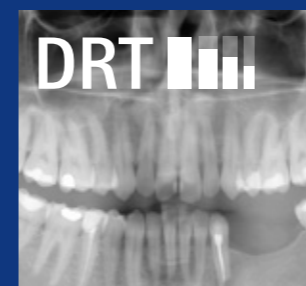

Dose Reduction Technology™ for optimised image quality with very low radiation dose

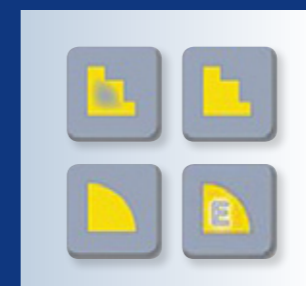

Four individual image resolution options (Dose reduction – DRT, Standard, High Res, Endo)

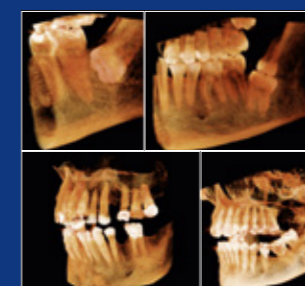

Maximum operational flexibility with four FOV – up to FOV 8 x Ø 15 cm (optional)



Simple, intuitive operation with the new touch-panel user interface



Taking 3D adaptability to the max – with four different FOV sizes.*

Benefit from the large FOV selection.

The four different field of view sizes secure reliable 3D diagnostics in the entire oral region. They provide indication-related and versatile application possibilities for the daily routine – from implantology to oral surgery.

* 8 x 15 is optional



5 x Ø 5 cm
for local diagnostics:

- Planning of single implants
- Third molars extractions
- Impacted teeth
- Endodontics

6 x Ø 8 cm
for the complete dental arch:

- Planning of multiple implants in one jaw
- Surgical guides

8 x Ø 8 cm
for both dental arches and sections of the sinus maxillaris:

- Planning multiple implants in both jaws
- Surgical guides
- Analysis of sinus maxillaris
- TMJ diagnostics

8 x Ø 15 cm (optional and upgradable)
for the entire upper and lower jaw regions:

- Analysis of the sinus maxillaris
- TMJ diagnostics
- Airway analysis
- „The 3D Panoramic“**

**With special positioning

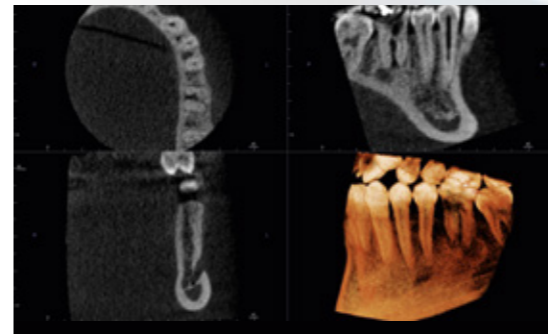

Volume 5 x Ø 5 cm with DRT

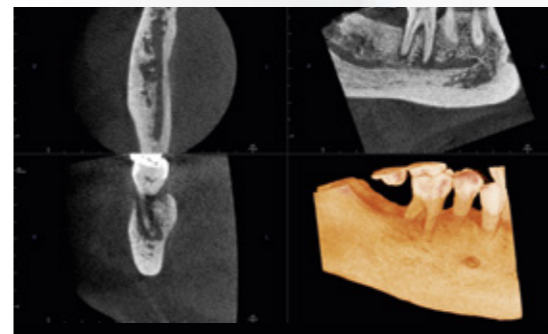

Volume 5 x Ø 5 cm in Endo Mode



You adapt to every patient – your GXDP-800™ unit does, too.

A selection of FOV resolutions for every indication.

You can choose from four resolutions for all FOV sizes.

The Endo option is additionally available with a 5 x Ø 5 cm FOV. All modes provide the appropriate resolution for the respective indication.



Dose Reduction Technology™ (DRT) – for 3D images with radiation comparable to doses of 2D images



Standard Mode – with optimised patient dose for most clinical cases



High Resolution Mode – for extremely sharp images with highly detailed diagnostic information



Endo Mode – with 85µm voxel size and SRT function, specially designed for endodontics

Dose Reduction Technology™ – The sensible solution for sensitive cases.

The unique Dose Reduction Technology™ (DRT) of the GXDP-800™ CBCT device creates optimised 3D X-ray images with a low radiation dose. Dose reduction is a real benefit for dose sensitive clinical cases such as post op images, implant planning, and pediatric.

5 x Ø 5 cm 3D image with DRT.

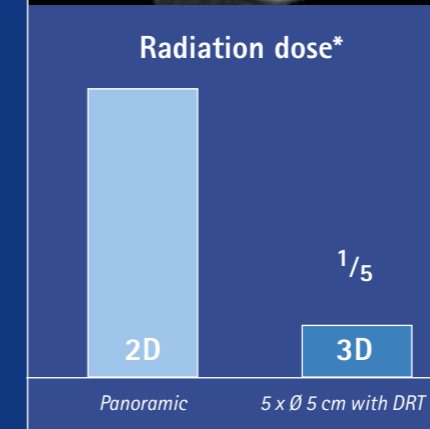

8 x Ø 15 cm 3D panorama view with DRT.

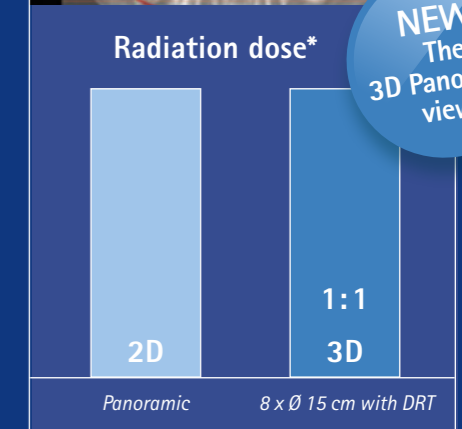
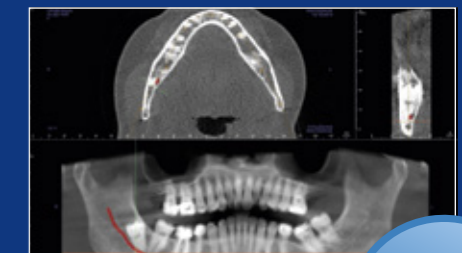

NEW!
The 3D Panoramic view!

* According to the dose study by John B. Ludlow, February 2014



Outstanding images. Every single time.



Easy Position™ – Stable and secure patient positioning.

The stable five-point positioning system with headrest, temple support, chin rest and bite block prevents patient movement. Up to 10 laser lights facilitate a precise patient positioning (3 x panoramic, 1 x cephalometric, 1 x TMJ, 5 x 3D). The open design allows for positioning and operation from the left or right.

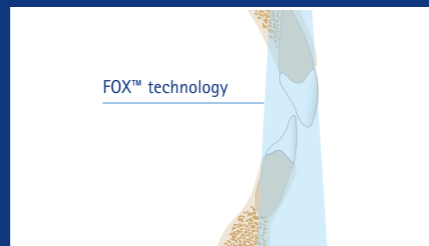

Homogeneous imaging thanks to FOX™ technology.

(FOX = Focus Optimized X-ray)

The FOX™ beam takes into consideration the varied absorption of the human anatomy better than a standard parallel beam and ensures a homogeneous image. This combines more effective penetration of the maxilla with a wider image layer in the mandible.



SmartMotion Technology™ for optimized image quality.

Adaptable motion technology adjusts the X-ray beam allowing changes in the projected geometry to optimise the quality of the image. Quality levels are further improved by SmartMotion's spinal compensation.



43% to 32% dose with pediatric cephalometric imaging



52% to 38% dose with standard lateral cephalometric imaging

Automatic radiation adaptation for cephalometric imaging with AFC.

AFC – Automatic Facial Contour: For orthodontic images the AFC lowers the exposure factors for the craniofacial area to expose also the soft tissue. Together with the field size collimation a significant dose reduction can be achieved.

Cephalometric imaging with various settings. (optional and upgradable)

The cephalometric option of the GXDP-800™ unit offers you various projections, cranial-lateral, AP / PA, cranial-excentric and carpus.



PerfectScout™ Function – The perfect way to preview.

Precise positioning with PerfectScout™ function.

With the aid of the new user interface the selected field of view is simply positioned on the dental arch for a 3D image. The PerfectScout™ function creates two 2D preview images (lateral/frontal) and enables the precise positioning of the region of interest. The freely selectable positioning of the FoV along the dental arch improves the positioning of the patient, especially for small FoV sizes.



PerfectScout™ function creates two 2D preview images.

SRT™ Function – Get a clearer view.

The Scatter Reduction Technology™ (SRT) reduces the influence of scattered radiation arising from compact structures in the exposed area. This specifically improves the image quality of teeth with filled root canals.

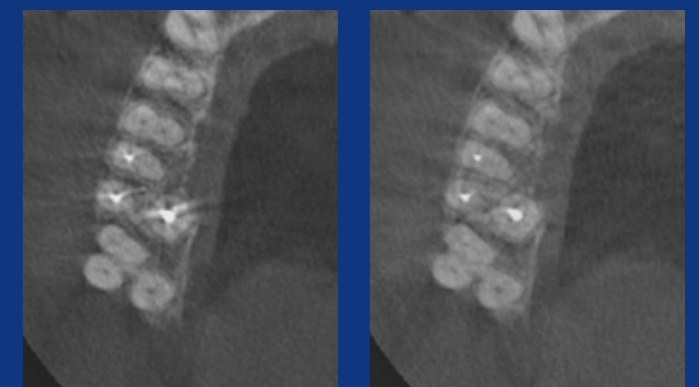

without SRT

with SRT



The 10" touch panel – Simple and intuitive.

Focus on user friendliness.

The new user interface of the GXDP-800™ touch panel is designed for a simple and intuitive operation. Its clear layout and the modern design, together with easily recognisable icons and images, makes operation easy and comfortable. No matter what program application you select, the large touch panel guarantees simple operation, high operational safety, and is significantly time saving.



10" Touch panel with a new user interface supports simple and safe use. (with optional 8x15 FOV)

Standard cephalometric mode with AFC

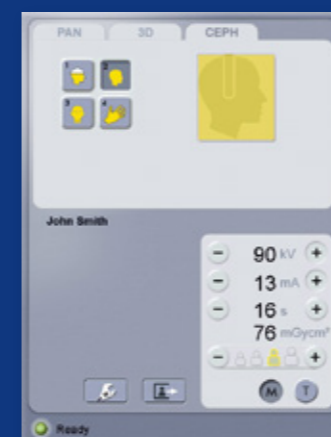

6 x 8 cm 3D



8 x 15 cm 3D (optional)

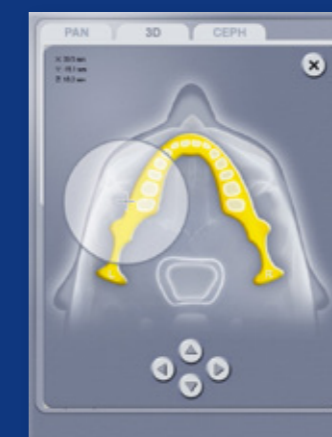
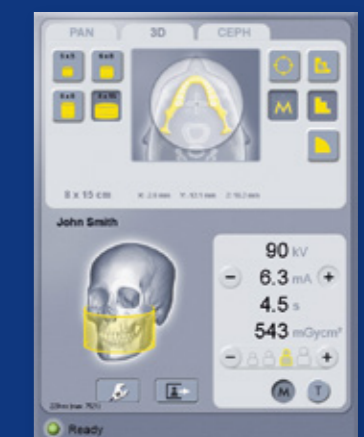

So many choices – Always great results.

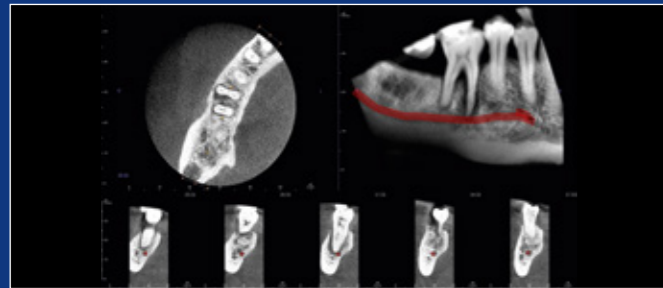

Precise diagnostics with 5 x Ø5 cm and 85 µm ENDO resolution. Detailed interpretation of the canal structures and the periodontal details.

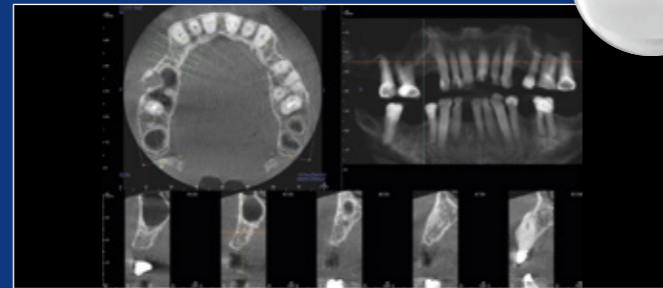

The popular jaw presentation 8 x Ø 8 cm upper / lower jaw with root tips and sectional sinuses with only 16 µSv in DRT mode. Suitable for oral surgery.

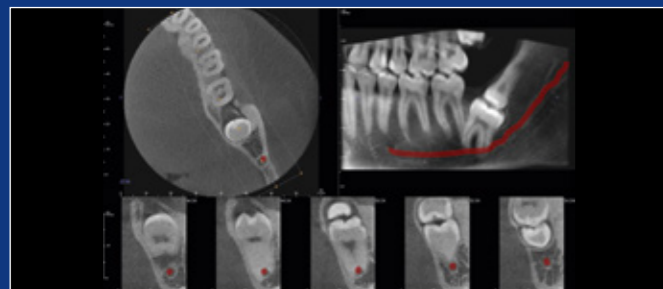

Reduced height with 6 x Ø 8 cm gives full diagnostic value for one jaw.



The new "3D panoramic" view with optional 8 x Ø15 cm – TMJ upper and lower jaw and sections of the sinuses in 3D with the dose comparable to a 2D panoramic layer image.



Standard panoramic of an adult patient. There is a height and width collimation to reduce the dose for pediatrics.



The Orthogonal program reduces overlapping of the teeth.



Programs for lateral and frontal TMJ images with the mouth opened or closed.

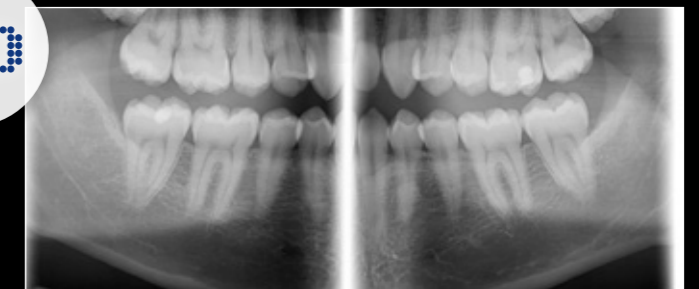

Special program with specific segmentation and collimation to produce occlusal images.

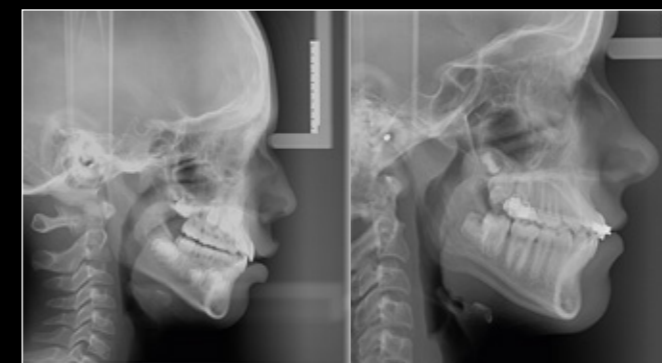

Lateral cephalometric images can be created in two different heights 18 cm and 22 cm.



Posterior-anterior cephalometric image. The ear-rods include markings to secure the centric position.

Technical Specifications

Gendex GXDP-800™

X-ray	Multipuls DC, 75–150 kHz
Focal spot	0.5 mm IEC 336
Tube voltage	57 – 90 kV
Tube current	3.2 – 16 mA
Filtering	3.2 mm Al

Panoramic

Image receiver	CMOS
Pixel size (sensor)	100 µm
Acquisition time	8.6 – 16.1 s
Image height	120 – 151 mm

Cephalometric

Image receiver	CMOS
Pixel size (sensor)	100 µm
Acquisition time	6.5 s – 20 s
Image height	180 mm and 220 mm
Image width	Lateral: 240 mm; Posterior - Anterior: 240 mm

3D

Image receiver	CMOS
Voxel size	85 µm – 420 µm
Acquisition time	10 – 20 s
Exposure time	1.2 – 9 seconds, pulsed
Volume sizes (H x Ø)	50 x 50 mm, 61 x 78 mm, 78 x 78 mm, 78 x 150 mm (optional)

Minimum requirements for the acquisition computer

Processor	2.5 GHz Dual Core or higher
Memory	8 GB RAM or more
Hard Disk	500 GB or more
Card slot	PCI-Express x 16, full length
Network	Gigabit network, 1000 Base-T
Mains adapter	500 W minimum
Operating system	Windows 7, 8 or 8.1 – 64-bit required

You will find the complete software specifications and requirements in the GXDP-800 installation manual. If you have any questions, please contact your local dental dealer

Gendex, GXDP-800, Dose Reduction Technology, EasyPosition, FOX, SmartMotion and Scatter Reduction Technology are trademarks of Gendex Dental Systems in the United States and/or other countries.

Unit Dimensions

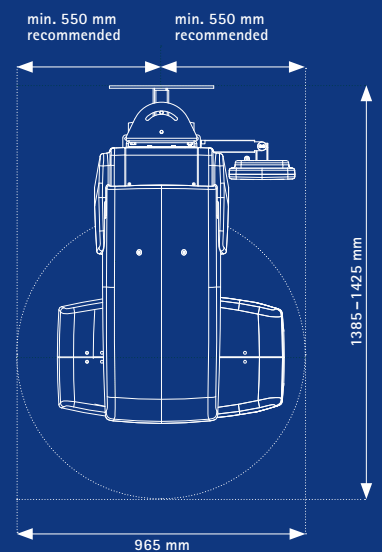
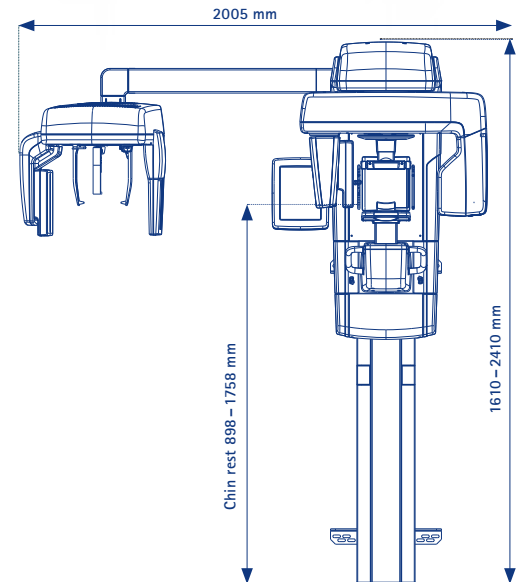

KaVo Dental GmbH
 D-88400 Biberach/Riss
 Telephone: +49 7351 56-0
 Fax: +49 7351 56-1488
 www.kavo.com



Scan here for more information

